

UNTHA

shredding technology

The reliable brand!

RS

The world's most robust
four shaft shredder



RS150



WELCOME TO UNTHA UK – YOUR SHREDDING PARTNER

If you're looking for an experienced shredding specialist that can supply world-class technology, configured to suit the exact requirements of your [waste management/recycling] operations, you've come to the right place.

BUT THERE'S MORE TO UNTHA THAN MACHINERY.

The level of knowledge and expertise that goes in to researching, designing and engineering our state-of-the-art shredders is also mirrored in the customer support services that we provide. That means we're not just a machinery vendor. We're also a friendly, forward-thinking and hard-working team of waste experts committed to becoming your shredding partner long after the sale.

WE OFFER:

- > Shredder trials
- > Operator training
- > Service and maintenance packages
- > Spear and wear parts
- > Finance
- > Complete systems solutions

The list goes on, but ultimately, your long-term satisfaction is our priority.

UNTHA UK – Your reliable shredding partner

INTRODUCING THE RS150

Designed specifically for operators handling large volumes of waste or particularly difficult materials, the RS150 is the world's most robust four shaft shredder for extreme applications.

The slow speed, high torque technology with energy-saving Eco Drive, translates into a range of bottom-line benefits – unrivalled process uptime, impressive throughputs, low power consumption, protection from unshreddables, low wear, maintenance simplicity, low noise and minimal dust generation.

Particle homogeneity is also guaranteed, however bulky the waste, thanks to the RS150's ability to pre-shred and re-shred in a single pass. This maximises the performance of any other separation equipment and provides an even greater return from your shredding equipment. The overall result is a heavy-duty machine built to withstand the pressures of even the most complex shredding scenarios. That means more plant availability, less operational disruption and a swift return on investment.

WASTE & RECYCLING APPLICATIONS:

- > Metals
- > WEEE
- > Hazardous waste
- > Chemical waste
- > Cables
- > Small domestic appliances
- > Large domestic appliances
- > and more

**DID YOU
KNOW..?**

You can trial this
shredder using your
own materials.
Enquire today!

QUALITY FEATURES

High availability

- > integrated electronic shut-down for unshreddable items
- > resistant to foreign material due to low speed cutting shafts
- > multiple shaft bearings (A) for extra rigidity
- > multi-stage sealing system (B) protecting gears and bearings
- > integrated and easy-to-replace cutting chamber bulkhead walls (C)
- > straight forward design (no hydraulics, couplings, etc.) ensures reliable operation
- > rugged, reinforced steel frame
- > cutting disks with integral collar (no separate spacers) distributes cutting force over wide area

Operational advantages

- > reliable tooth belt drive (E) with two independent motors and rugged, heavy-duty gears (F)
- > belt drive provides optimum shaft speed
- > consistent final particle size
- > one step pre- and re-shredding
- > self feeding for most materials – no ram required
- > quick change screen system
- > low noise and dust generation

Low noise and dust pollution

- > by low-speed cutting shafts

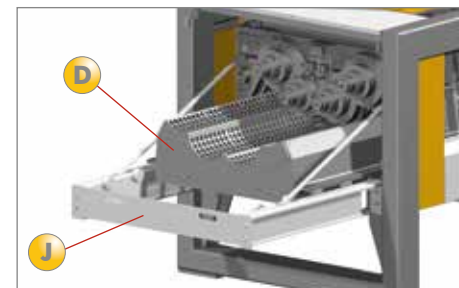
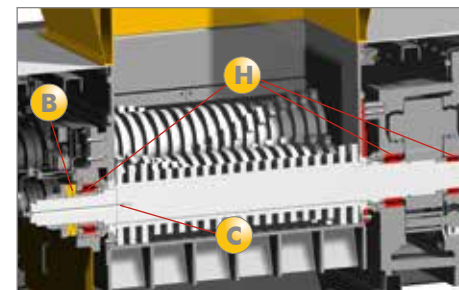
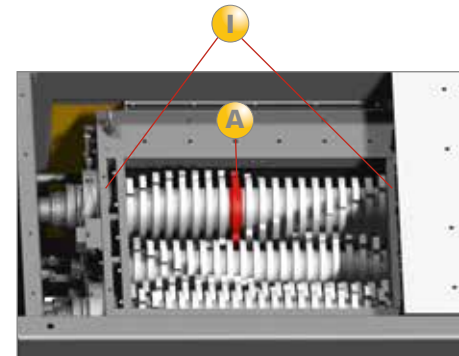



ENGINEERED WITH YOUR ROI IN MIND. THE CUTTERS IN THE RS150 CAN BE REFURBISHED FOR ADDED LONGEVITY AND REDUCED EXPENDITURE!

Functional design

- > can be loaded from all sides
- > more than 350 cutting system configurations available
- > modular system allows for tailor made solutions
- > compact design integrates into complex installations without difficulty
- > rugged cast iron frame **G**

Unmatched in productivity

- > very large screen area ensures high throughput
- > high torque drive easily handles tough materials
- > low downtime with high availability

Options

- > hydraulic ram for bulky materials
- > variable frequency drive (VFD) speed control for adjustable throughput and reduction of start-up peaks
- > screw conveyor for efficient discharge of shredded material
- > automatic central lubrication system
- > active shaft ventilation **H** for increased cutter life
- > dynamic cutting disc pre-loading system **I** for easy change-out
- > wear plates
- > „UNTHA Carefree package“

“The RS150 will completely revolutionise our approach to recycling... with more material going back into the industry for reprocessing, and more revenue yield for our business.

This machine will also keep power consumption low, which minimises our carbon footprint and saves on energy costs. You wouldn't expect these efficiencies within such a heavy duty machine of this size.”

Tony Hughes, Managing Director, LKM Recycling



OUR FACILITIES:

When you invest in an UNTHA shredder, you don't just receive a piece of machinery. You also have access to a range of facilities at our North Yorkshire headquarters, including:

- > **OUR 'TEST CENTRE'**, which allows you to trial our equipment and conduct feasibility studies using your own materials.
- > **ON-SITE TRAINING COURSES**, developed specifically for our shredders and held away from your premises (if you wish), to ensure your staff are rigorously equipped with the skills they need to efficiently run, maintain and optimise your machine.
- > **VIP INVITATIONS TO OUR PROGRAMME OF CONFERENCES**, with guest seminars and learning sessions delivered by notable industry figures.





CUSTOMER SUPPORT SERVICES:

Your shredder is an asset engineered to deliver a return on investment long into the future. That's why we're as renowned for our customer support services, as we are our technology. These services include:

- > **PREVENTATIVE MAINTENANCE PLANS** and **SERVICING REGIMES** tailored to your application.
- > **CUTTER** (and **SCREEN**) plus complete machine overhauls.
- > The **SUPPLY OF HIGH QUALITY, READILY-AVAILABLE** spare and wear parts.
- > An **ENGINEERING HELPLINE** with remote diagnostics, if you encounter any issues or want to optimise the performance of your shredder.

Want to avoid fluctuating after sales costs? Talk to us about devising an affordable plan – and one consistent payment – to suit your needs.



BUYING AN UNTHA SHREDDER

Our shredders have been specifically designed with value and return on investment in mind. But our commitment to saving you money doesn't stop there. We also offer a range of flexible procurement options to suit the requirements of YOUR business.

PURCHASE OUTRIGHT

If you have the capital available to purchase the machine outright we will prepare a comprehensive quote inclusive of the shredding technology itself and the commissioning project. We can also factor in a customer support package tailored to your operational needs, so that you can benefit from the expertise and assistance of our dedicated after sales team long after the initial installation.

FINANCE AVAILABLE

If you would prefer to spread the cost of the investment, we work with some of the UK's leading finance partners for every level of shredding project. That means one manageable, all-inclusive monthly payment for a term to suit you, with no hidden costs or unexpected surprises.

With knowledge of all the latest grants available, our finance partners can also advise how you can access funding to make your investment even more affordable.

Talk to us about your budget and preferred procurement method and we'll tailor our proposal accordingly.

RS150

4-shaft shredding system

TECHNICAL DATA		RS150-1500	RS150-1500
Driving Power	kW	4 x 78	4 x 45
Charging hole	mm	1,500 x 1,260	1,500 x 1,260
No. of cutting shafts		4	4
Speed main shafts	rpm	15 - 30	25
Speed secondary shafts	rpm	17 - 34	28
Ø Perforated screen	mm	50 - 100	50 - 100
Direct drive		yes	yes
Drive type		UNTHA Eco Drive	Asynchron
Weight	kg	ca. 22,000	ca. 21,000

All dimensions in mm.

40 years of expertise.

More than 9,000 shredders in daily operation!

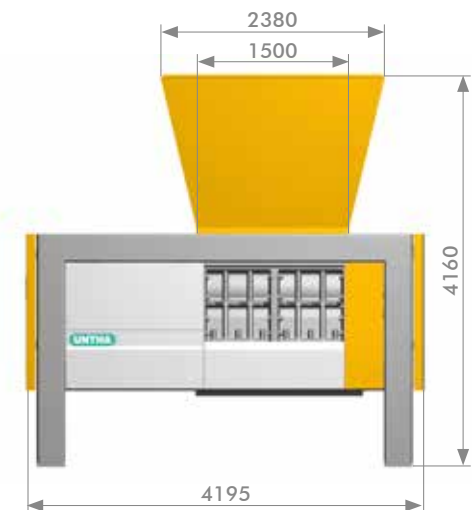
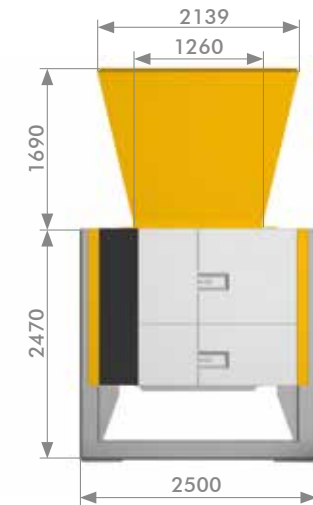



UNTHA

shredding technology

The reliable brand!



UNTHA shredding technology

Kellau 141
A-5431 Kuchl / Salzburg, Austria
Tel +43 6244 7016 0
Fax +43 6244 7016 1
info@untha.com
www.untha.com

UNTHA UK LTD
Excel House, Becklands Close,
Bar Lane, Roecliffe, Boroughbridge
YO51 9NR York
United Kingdom

Phone +44 845 450 5388
Fax +44 845 450 5389
sales@untha.co.uk
www.untha.co.uk

